

# RSP SQUAT. Componentes

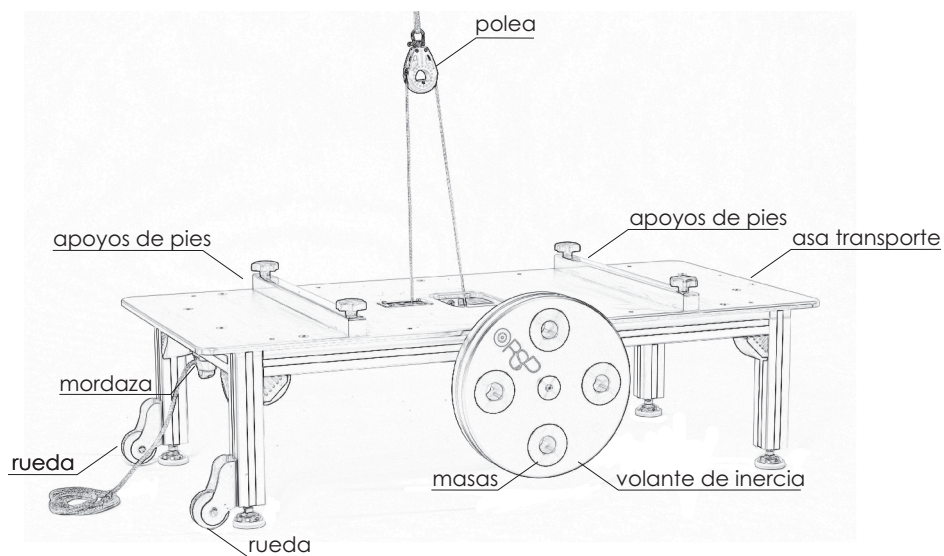

# RSP SQUAT. Instalación

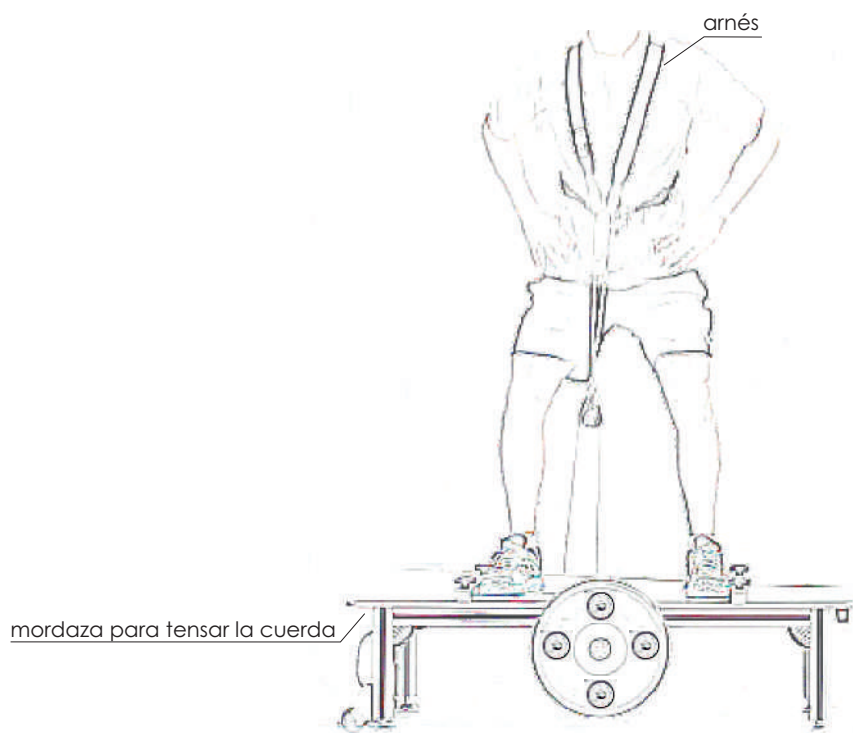

Colocación masas:

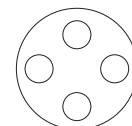

sin masas

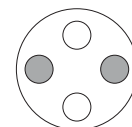

2 masas

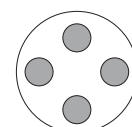

4 masas

Antes de empezar de pie encima de la máquina totalmente estirado, debemos de tensar la cuerda.